

DEMAND CONTROL VENTILATION

QUIET *Flow*
DCV

Dimensional Data

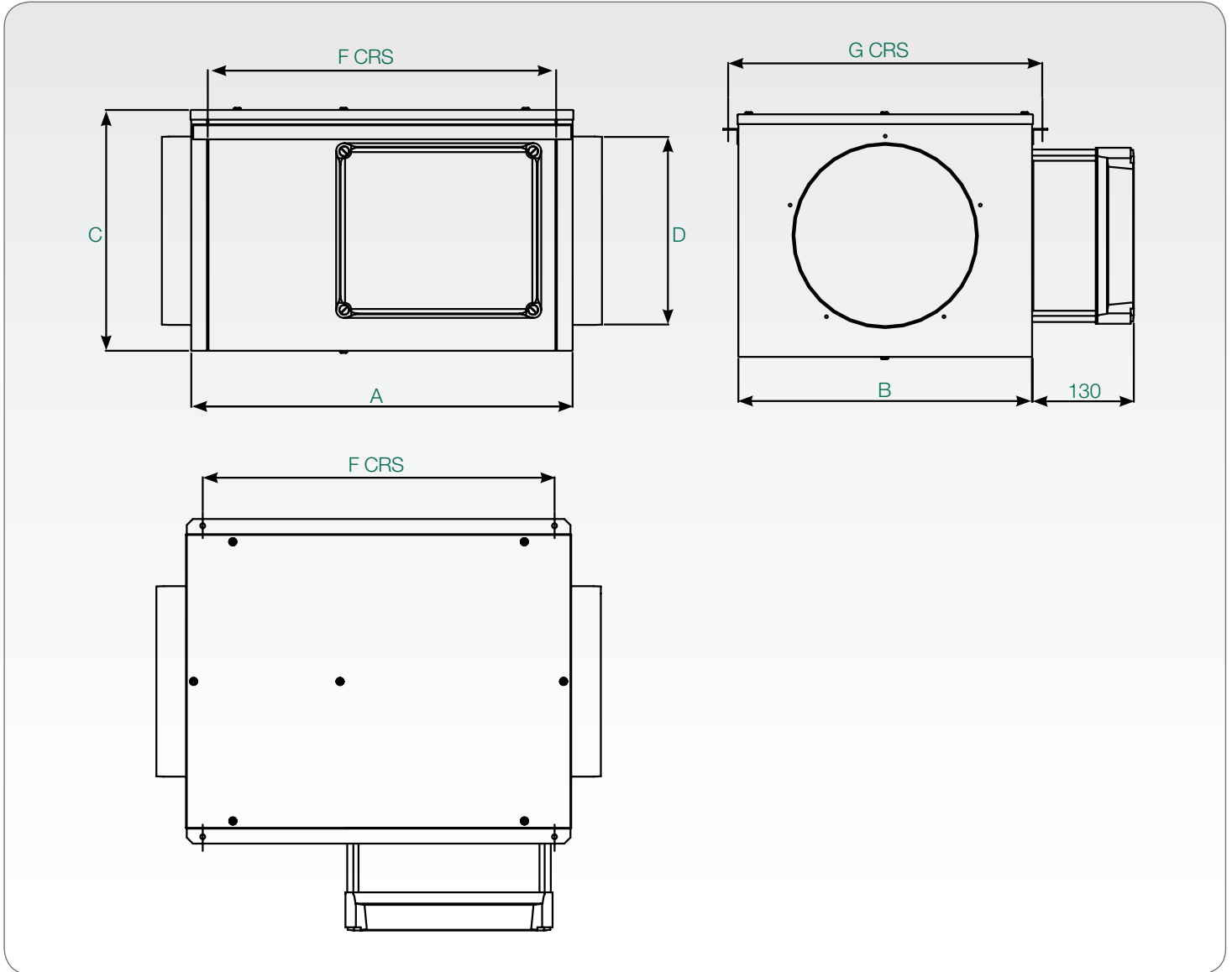

Model	A	B	C	D	F	G	Weight kg
SQS100-DCV	514	354	262	100	435	375	19
SQS125-DCV	514	354	262	125	435	375	19
SQS150-DCV	514	354	262	150	435	375	19
SQS200-DCV	589	401	302	200	550	421	21
SQS250-DCV	589	401	332	250	550	421	23
SQS315-DCV	640	490	401	315	580	510	30
SQS400-DCV	705	575	473	400	580	620	41
SQS500-DCV	885	755	602	500	700	800	68

DEMAND CONTROL VENTILATION