



Compact CM Installation and Maintenance Instructions

**THESE INSTRUCTIONS MUST BE READ FULLY BEFORE
COMMENCING INSTALLATION**

Code	Supply	FL Amps	Output kW	r/min
CM315/4-1	230V/1Ph/50Hz	0.90	0.09	1390
CM350/4-1	230V/1Ph/50Hz	0.90	0.09	1330
CM400/4-1	230V/1Ph/50Hz	1.80	0.25	1375
CM450/6-1	230V/1Ph/50Hz	1.05	0.12	850
CM450/4-1	230V/1Ph/50Hz	1.80	0.25	1300
CM500/6-1	230V/1Ph/50Hz	1.55	0.18	860
CM500/4-1	230V/1Ph/50Hz	3.60	0.55	1350
CM560/6-1	230V/1Ph/50Hz	2.20	0.25	875
CM560/4-1	230V/1Ph/50Hz	4.90	0.75	1350
CM630/6-1	230V/1Ph/50Hz	6.00	0.55	850
CM630/4-1	230V/1Ph/50Hz	7.90	1.1	1310

Code	Supply	FL Amps	Output kW	r/min
CM315/4-3	400V/3Ph/50Hz	0.50	0.12	1390
CM350/4-3	400V/3Ph/50Hz	0.50	0.12	1330
CM400/4-3	400V/3Ph/50Hz	1.40	0.37	1375
CM450/6-3	400V/3Ph/50Hz	0.68	0.18	850
CM450/4-3	400V/3Ph/50Hz	1.40	0.37	1300
CM500/6-3	400V/3Ph/50Hz	0.94	0.25	830
CM500/4-3	400V/3Ph/50Hz	1.75	0.55	1320
CM560/6-3	400V/3Ph/50Hz	0.94	0.25	830
CM560/4-3	400V/3Ph/50Hz	2.00	0.75	1320
CM630/6-3	400V/3Ph/50Hz	1.90	0.55	850
CM630/4-3	400V/3Ph/50Hz	4.30	1.5	1320

Code	A	B	C	D	E	Weight kg
CM315	315	310	88	10	380	5
CM350	350	345	103	10	415	6
CM400	400	395	103	10	470	8
CM450	450	445	114	10	520	8
CM500	500	495	114	10	580	14
CM560	560	555	119	10	650	16
CM630	630	625	121	10	730	20

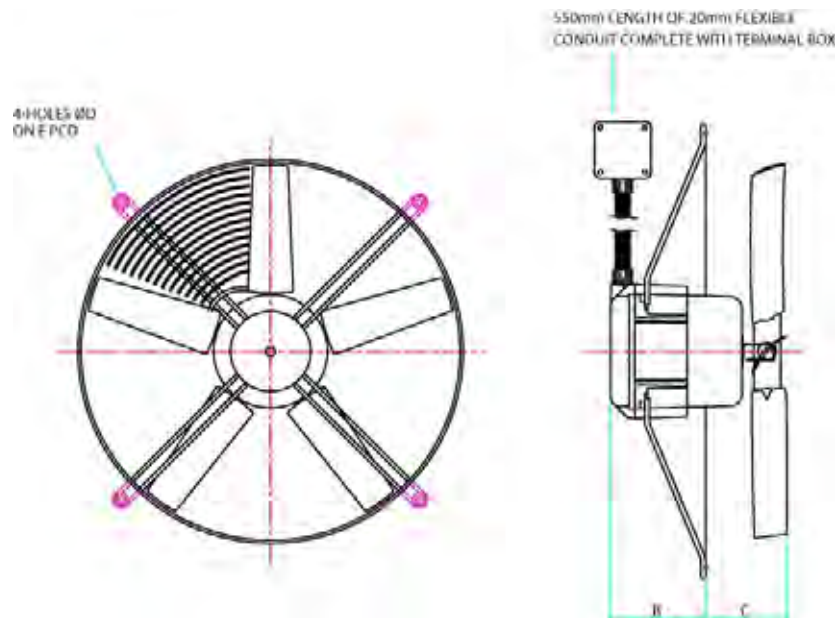

1.0 GENERAL

- 1.1 It is important these Installation and Maintenance Instructions are fully adhered to.
- 1.2 Full details of the unit supplied are shown on the product nameplate. If in doubt about any detail contact Elta Fans Ltd or its agents for clarification.
- 1.3 All electrical installation must be carried out by suitably qualified and competent personnel in accordance with all current statutory requirements.
- 1.4 These instructions cover only the Elta Fans Ltd product and do not include the supply or installation of any safety equipment that may be required e.g. adequate guarding or protection from rotating parts and proper electrical isolation.
- 1.5 Any declarations made by Elta Fans Ltd about product installation and safety, are dependant on the fan equipment being used within installations which themselves meet the requirements of the relevant Standards and Directives of your region.
- 1.6 The fan is designed for use in an ambient temperature of -20°C up to $+70^{\circ}\text{C}$ fixed speed, -20°C up to $+50^{\circ}\text{C}$ when used with a speed controller and up to 95% relative humidity. The fan is not suitable for corrosive or explosive atmospheres.
- 1.7 The installer should provide easy access to the fan to facilitate future maintenance.
- 1.8 The installer should ensure the fan is adequately supported.
- 1.9 This product is not intended for use by persons (including children) with reduced physical, sensory or mental capabilities, or lack of experience and knowledge, unless they have been given supervision or instruction concerning use of the product by a person responsible for their safety. Children should be supervised to ensure that they do not play with the product.

2.0 INSTALLATION

WARNING – The fan must be isolated from the power supply during installation and maintenance. The fan must be earthed in accordance with the local regulations.

- 2.1 Upon receipt, the fan equipment should be visually inspected to check for any damage. Ensure that the impeller is free to rotate.
- 2.2 If there are any queries concerning the fan equipment, Elta Fans Ltd should be contacted prior to the installation.
- 2.3 The fan must be securely mounted in the desired position to suit the application.
The fan can be mounted at any angle.
- 2.4 Check the details on the motor rating plate to ensure that the correct power supply (voltage, frequency and phase) is available.
An incorrect power supply will lead to permanent damage to the fan motor.
- 2.5 Refer to the appropriate wiring diagram. Ensure that all earth connections are made.
- 2.6 Means for electrical disconnection must be incorporated in the wiring installation in accordance with the relevant wiring and electrical regulations.
- 2.7 Precaution must be taken to locate the exhaust discharge terminal so as to avoid the backflow of gases into the room from the open flue of gas or other fuel burning appliances.

3.0 START-UP

- 3.1 Before power is supplied to the unit, check that the wiring is correct as per the fan connection diagram.
- 3.2 At initial start-up, check that impeller rotation and airflow direction is correct.
- 3.3 Check that the motor amperage draw does not exceed the nameplate rating.

4.0 FAN MAINTENANCE

- 4.1 Inspection of the fan at least once every 12 months is recommended to ensure that the motor, fan blades, and supporting guards, are clean. Any build up of dust and deposits on the blades or guards should be removed using a non-abrasive cleaner.
- 4.2 All fastenings should be checked for tightness. In addition, all rotating items should be checked.
- 4.3 Bearings are of the 'sealed for life' type and will not need a detailed inspection.

WARNING – This fan is fitted with an auto-reset thermal contact which switches the fan off in the event of a fault condition.

Once the motor cools down the fan may start unexpectedly.

Only a suitably qualified and competent person may carry out maintenance after the electrical supply has been isolated.

WIRING

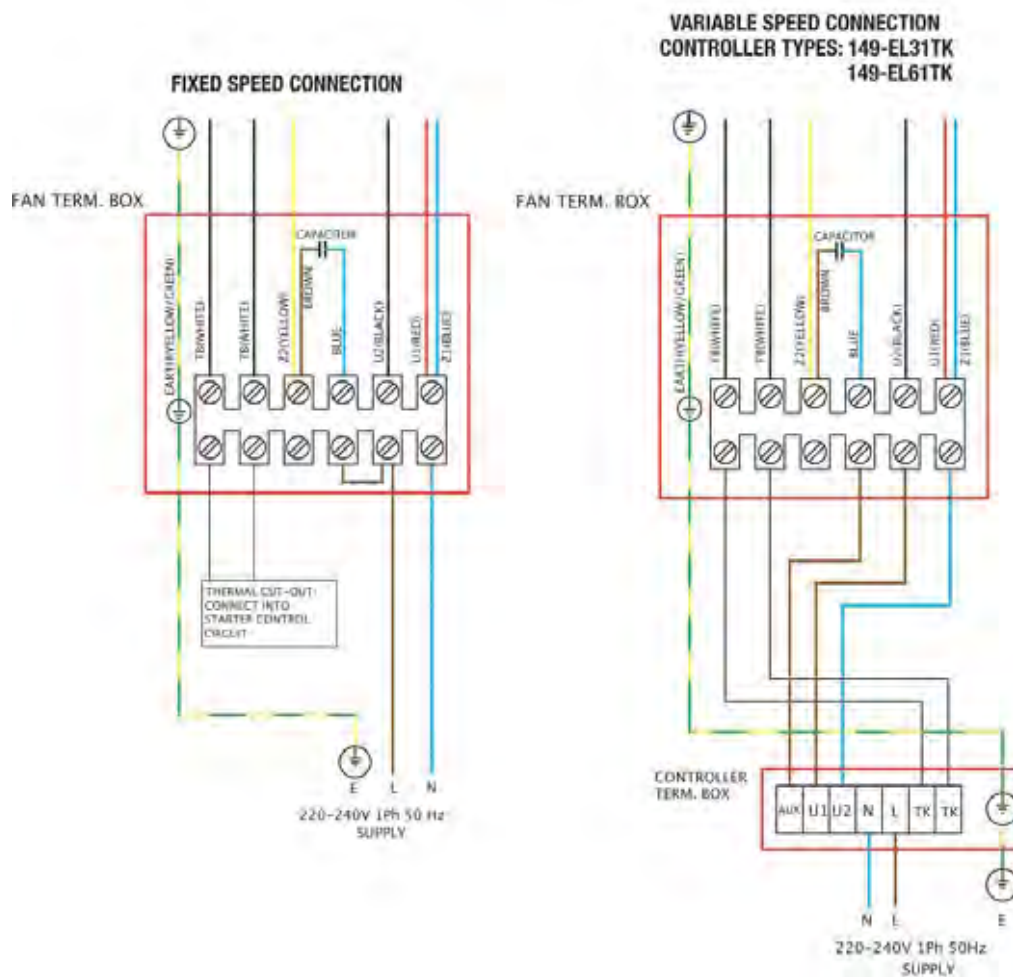

VARIABLE SPEED CONNECTION
CONTROLLER TYPES: 149-TC12
149-TC14
149-TC18
149-TC110

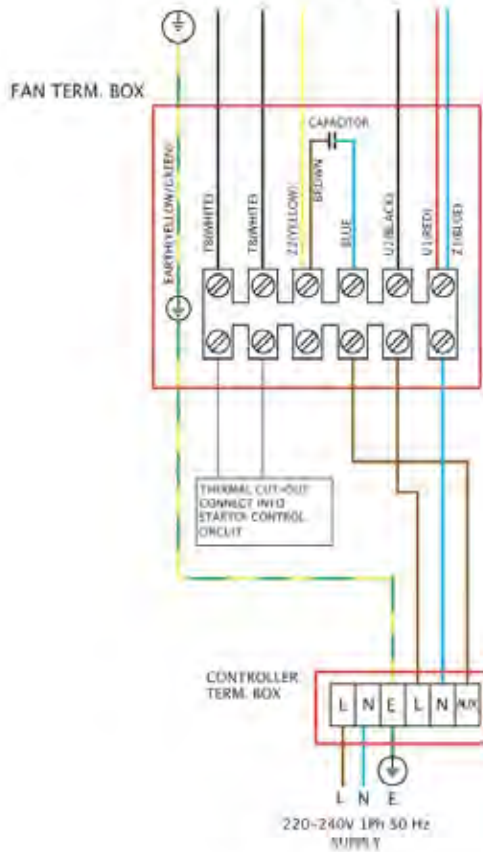

FIXED SPEED CONNECTION

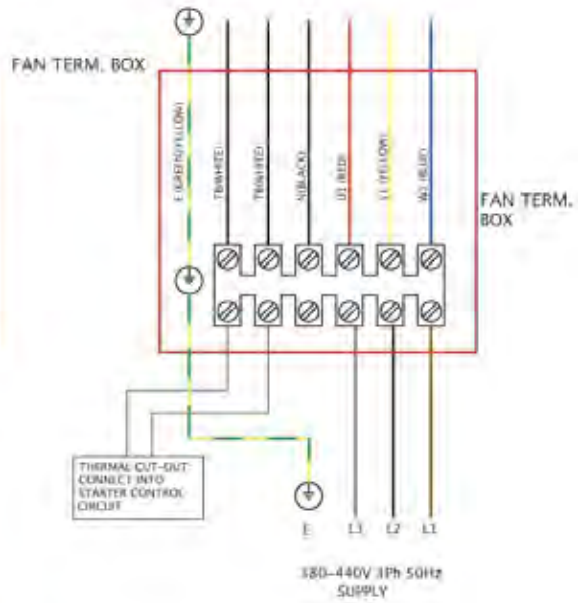

VARIABLE SPEED CONNECTION
CONTROLLER TYPE: 149-TC3**

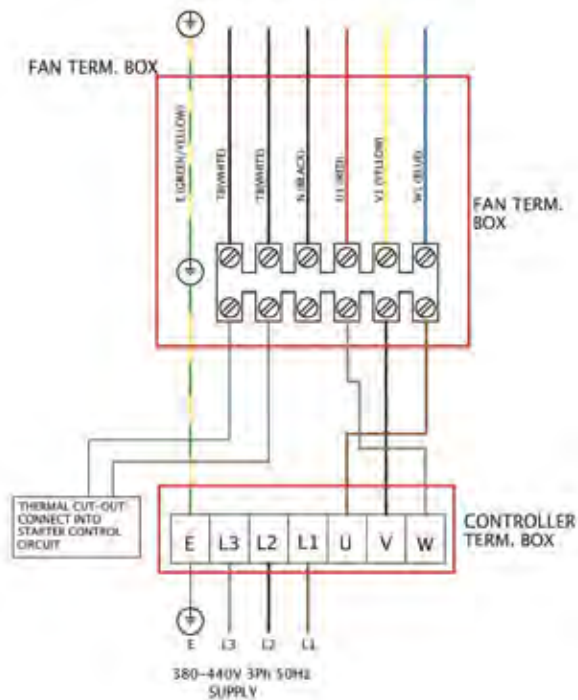

GUARANTEE

Elta Fans Ltd will, free of charge, within a period of 1 year from the date of despatch from their works, repair or at its option replace any goods which are proved to have defects as a result of defective materials or workmanship. The goods MUST be returned to Elta Fans Ltd carriage paid for examination.

Elta Fans Ltd

17 Barnes Wallis Road
Segensworth East Industrial Estate
Fareham, Hampshire, PO15 5ST, United Kingdom

Visit: eltafans.com

e-mail: mailbox@eltafans.co.uk

Applied Technology: **Tel:** +44(0) 1489 566500

Fax: +44(0) 1489 566555

Building Services: **Tel:** +44(0) 1384 275800

Fax: +44(0) 1384 275810

Export: **Tel:** +44(0) 1489 566500

Fax: +44(0) 1489 566555

CM Inst Issue 1: 3-01-08