

Portacooler



Portable **Axial Flow Fans**

features & benefits



Portacooler SPC

Portacooler is a range of fully portable enclosed axial fans, ideal for localised free-standing cooling or ventilation which comes complete with guards fitted for safety, integral speed controller and a plug and lead so the fan is ready to run.

- Maximum air flow 3.0 m³/s.
- 3 sizes, 350mm, 450mm & 560mm.
- Free standing.
- Variable fan position.
- Highly efficient, lightweight induction motors.
- Motors protected to IP55, with Class F insulation.
- Safety guards front and rear.
- Suitable for operating temperatures up to 50°C.
- Flying lead with 13A UK plug.
- Supplied ready to run.
- One piece tubular frame.
- Saddle feet fitted to protect frame.
- Variable speed control.
- Rugged construction.

Features & Benefits

Range – Three sizes available so you can achieve the desired air volumes.

Material strength – The fan casing is a robust construction with all parts treated to ensure full corrosion protection, with casing and motors epoxy powder coated and guards are zinc plated.

Performance – Adjustable pitch aerodynamic impellers designed for maximum performance as it provides a good velocity profile (or throw) over long distances.

Adjustable – The SPC has a ‘fan angle adjuster’ for variable setting, which allows the person operating the unit to adjust the direction of the air flow to individual requirements.

Motors – These are protected to IP55 which means they are highly resistant to dust and water ingress.

Cost effective – Very efficient for moving high volumes of air.

Safety – All motors are all fitted with integral thermal over-load protection preventing the motor from overheating.

Stability – A sturdy mounting frame on durable rubber support pads means a very stable unit whilst operating in populated areas.

Convenience – Each unit is supplied with a flying lead and a 13A UK plug, so you can position the unit where it is convenient.

Speed controllable – Each unit is supplied with a flying lead and a 13A UK plug, so you can position the unit where it is convenient.

Tested to the very latest standards – SMF units are tested to ISO 5801:1997 (airside performance) and to BS 848 Pt 2:1985 (sound performance) at Elta Fans own test facility, meaning accurate, up to date information on performance and noise data that can be relied upon.

Quality assurance – All units are designed and manufactured with procedures as defined in BS EN ISO 9001: 2000.

Reliability – Motors have sealed for life bearings.

Warranty – Each SPC has a one year warranty.

Applications

Temporary ventilation, construction sites, machine shops, welding bays, foundries, marquees, workshops, gymnasiums and large offices.

dimensional data

Portacooler SPC

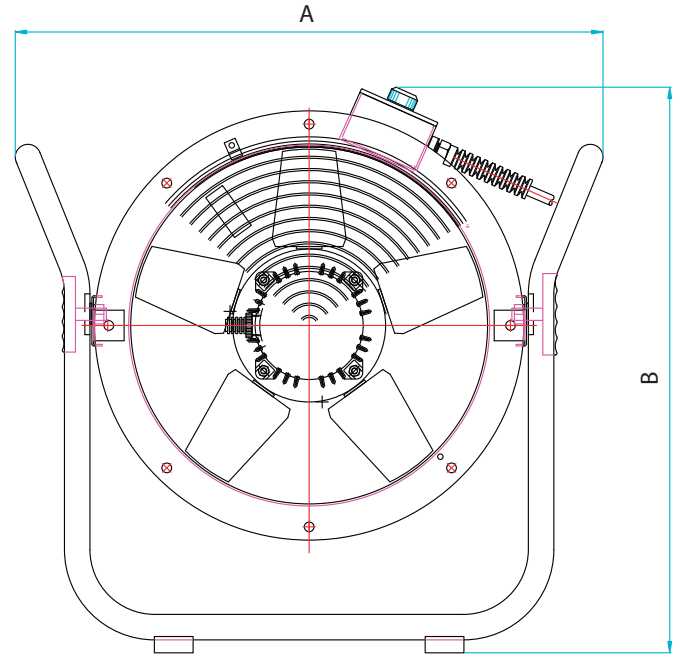
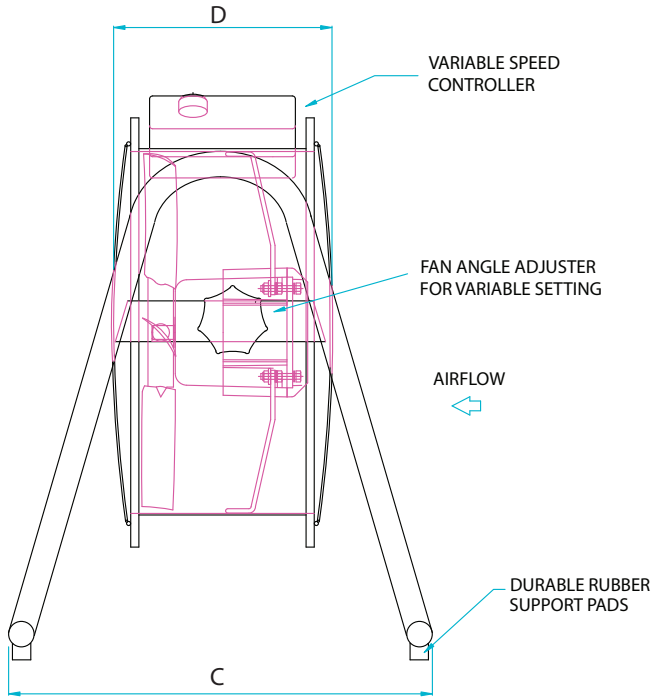

Product Code	A	B	C	D	Weight kg
SPC350/4-1	582	610	460	240	18
SPC450/4-1	671	678	460	254	24
SPC560/4-1	791	733	460	322	33

Portacooler SPC

Product Code	Max Airflow m ³ /s	Max Speed r/min	FLC Amps	Output kW	Sound Level dBA@3m	Weight kg
SPC350/4-1	0.8	1320	0.90	0.09	56	18
SPC450/4-1	1.5	1300	1.80	0.25	63	24
SPC560/4-1	3.0	1350	4.90	0.75	69	33

Sound levels are average spherical free field values for comparative purposes only and will vary dependent on the fans surroundings.

Portacooler SPC

Product Code	63Hz	125Hz	250Hz	500Hz	1kHz	2kHz	4kHz	8kHz	dBA @ 3m
SPC350/4-1	73	85	79	75	69	66	62	56	56
SPC450/4-1	85	91	86	81	76	74	71	63	63
SPC560/4-1	84	90	89	91	81	79	74	70	69



Elta Fans Ltd - Applied Technology

17 Barnes Wallis Road,
Segensworth East Industrial Estate,
Fareham, Hampshire, P015 5ST, United Kingdom.

Visit: eltafans.com

e-mail: mailbox@eltafans.co.uk

Applied Technology:

Tel: +44 (0) 1489 566500

Fax: +44 (0) 1489 566555

Building Services:

Tel: +44 (0) 1384 275800

Fax: +44 (0) 1384 275810

Export:

Tel: +44 (0) 1489 566500

Fax: +44 (0) 1489 566555