



Industrial Wall Fan SE/SE LV Installation and Maintenance Instructions

**THESE INSTRUCTIONS MUST BE READ FULLY BEFORE
COMMENCING INSTALLATION**

Code	Supply	Watts	r/min	dBA @ 3m
SE100	230V/1Ph/50Hz	15	2500	39
SE125	230V/1Ph/50Hz	20	2450	41
SE150	230V/1Ph/50Hz	25	2100	43
SE100LV	12V	15	2500	39

Code	A	B	C	D	Weight kg
SE100	140	8	98	98	1.0
SE125	170	15	45	100	1.2
SE150	190	15	60	112	1.4
SE100LV	140	8	98	98	1.0

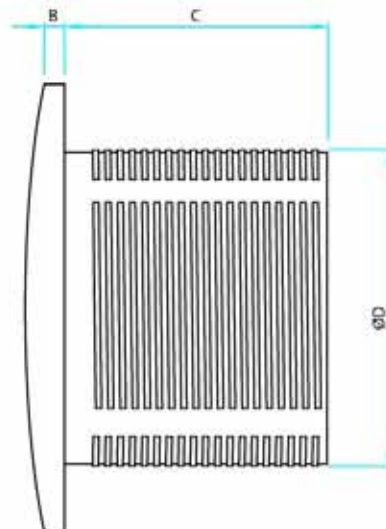
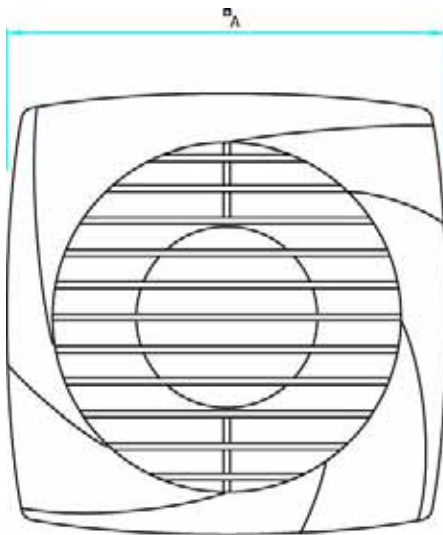

1.0 1.0 GENERAL

- 1.1. It is important these Installation and Maintenance Instructions are fully adhered to.
- 1.2. Full details of the unit supplied are shown on the product nameplate. If in doubt about any detail contact Elta Fans Ltd or its agents for clarification.
- 1.3. All electrical installation must be carried out by suitably qualified and competent personnel in accordance with all current statutory requirements.
- 1.4. These instructions cover only the Elta Fans Ltd product and do not include the supply or installation of any safety equipment that may be required e.g. adequate guarding or protection from rotating parts and proper electrical isolation.
- 1.5. Any declarations made by Elta Fans Ltd about product installation and safety, are dependant on the fan equipment being used within installations which themselves meet the requirements of the relevant Standards and Directives of your region.
- 1.6. The fan is designed for use in an ambient temperature of up to +40°C and up to 95% relative humidity. The fan is not suitable for corrosive or explosive atmospheres.
- 1.7. The fan should be installed at a minimum height of 2.3 m.
- 1.8. The installer should provide easy access to the fan to facilitate future maintenance.
- 1.9. The installer should ensure the fan is adequately supported.
- 1.10. This product is not intended for use by persons (including children) with reduced physical, sensory or mental capabilities, or lack of experience and knowledge, unless they have been given supervision or instruction concerning use of the product by a person responsible for their safety.
- 1.11. Children should be supervised to ensure that they do not play with the product.

2.0 THE RANGE

- 2.1. SE100, SE125, SE150, SE100LV - standard versions, should be operated by a remote switch
- 2.2. SE100C, SE125C, SE150C, SE100CLV- pull cord operated
- 2.3. SE100T, SE125T, SE150T, SE100TLV - with adjustable overrun timer -these fans should be operated by a remote switch which can also be used to control the room light. After the light/fan is switched off the fan will continue to run for the pre-set length of time.
- 2.4. SE100HT, SE125HT, SE150HT, SE100HTLV – with humidistat and timer - the adjustable, electronic humidistat is pre-set so that the fan will operate automatically when the moisture content in the room reaches 70% R.H. The fan will continue to operate until the Relative Humidity falls below the pre-set level and the timer has completed the overrun period. The fan can be operated by the pull cord (or by a remote switch) independently of the humidistat (a neon light indicates that the fan is operating in this mode). NOTE: the fan will continue to operate for a short period after the cord is pulled a second time, i.e. until the humidistat senses that the relative humidity in the room has fallen beneath the pre-set level and the timer has completed its overrun period.
- 2.5. All versions with "A" have delay action, slow moving shutters.
- 2.6. All versions with "LV" are LOW VOLTAGE (SELV). They MUST be installed using the transformer provided.
- 2.7. All versions with Timer or humidistat incorporate adjustable trimmers. The overrun period on timer can be adjusted upwards by turning the RED trimmer on the PC Board in a clockwise direction (from a minimum of 3 min to a maximum of 15 min). The Humidistat can be adjusted so that it starts to operate at a higher level or relative humidity by turning the BLUE trimmer in a clockwise direction (from a minimum of 40% to a maximum of 100%).
- 2.8. All versions with Humidistat incorporate a controlled temperature set-back allowing the humidistat to take into account variations in the ambient temperature and to avoid the fan switching on unnecessarily. This reduces fan operation at night.
- 2.9. All the fans (with the exception of the "LV" models) are splashproof to standard IPX4. The "LV" fans are rated IP57 enabling them to be safely installed in areas where a splashproof fan does not provide sufficient protection against water ingress.
- 2.10. All fans are extremely quiet in operation.

3.0 GENERAL INSTALLATION

WARNING – The fan must be isolated from the power supply during installation and maintenance. The fan is double insulated and does not require an earth connection.

- 3.1. Upon receipt, the fan equipment should be visually inspected to check for any damage. Ensure that the impeller is free to rotate.
- 3.2. If there are any queries concerning the fan equipment, Elta Fans Ltd should be contacted prior to the installation.
- 3.3. The fan is designed for wall, ceiling or window mounting in the desired position to suit the application.
- 3.4. Check the details on the motor rating plate to ensure that the correct power supply (voltage, frequency and phase) is available.
- 3.5. An incorrect power supply will lead to permanent damage to the fan motor.
- 3.6. Refer to the appropriate wiring diagram.
- 3.7. Means for electrical disconnection must be incorporated in the wiring installation in accordance with the relevant wiring and electrical regulations.
- 3.8. The printed circuit board in these fans has been protected to make it compatible with the majority of fluorescent fittings available on the market today. However, it is impossible to be aware of all the new products introduced. We suggest therefore that you contact your supplier to establish the compatibility of the fluorescent fitting you intend to use.
- 3.9. Precaution must be taken to locate the exhaust discharge terminal so as to avoid the backflow of gases into the room from the open flue of gas or other fuel burning appliances.

4.0 WALL MOUNTING INSTALLATION

- 4.1. Cut a 4"/10 cm, 5"/12 cm, 6"/15 cm hole (plus thickness of duct to be used, when necessary) in the wall.
- 4.2. Remove the front cover (A) by pressing the catch (1) with the tip of a screw-driver until it is free.
- 4.3. Pull the front cover forward and off main casing (B).
- 4.4. Loosen the screws (4) until the clips (5) are fully concealed in the housings (6). The spigot of the fan (D) can now be easily fitted into the duct.
- 4.5. Tighten the screws until the clips are firmly fixing the spigot of the fan (D) into the duct.
- 4.6. If necessary fix the fan to the wall using the screws and plugs provided via the four holes in the comers of the fan.
- 4.7. Connect the incoming wiring supply as indicated by the relevant wiring diagram.
- 4.8. Replace the front cover.

5.0 CEILING MOUNTING INSTALLATION

- 5.1. Cut a 4"/10 cm, 5"/12 cm, 6"/15 cm hole (plus thickness of duct to be used, when necessary) in the ceiling.
- 5.2. If installing fan into a plasterboard ceiling put the spigot of fan through the hole and secure using Ceiling Ring.
- 5.3. If the ceiling is of thicker construction follow wall installation instructions above.
- 5.4. Connect the incoming wiring supply as indicated by the relevant wiring diagram.
- 5.5. Replace the front cover.

6.0 WINDOW MOUNTING INSTALLATION

- 6.1. Cut a 4"/10 cm, 5"/12 cm, 6"/15 cm hole (plus thickness of duct to be used, when necessary) in the window.
- 6.2. Separate the locking ring by unclipping it from the grille section of the Window Kit.
- 6.3. Put fan through hole already cut in window and screw the locking ring on to fan spigot securing it firmly.
- 6.4. Clip back on the central flange/outer grille to the locking ring ensuring it lines up with the inside part of the fan.
- 6.5. Connect the incoming wiring supply as indicated by the relevant wiring diagram.
- 6.6. Replace the front cover.

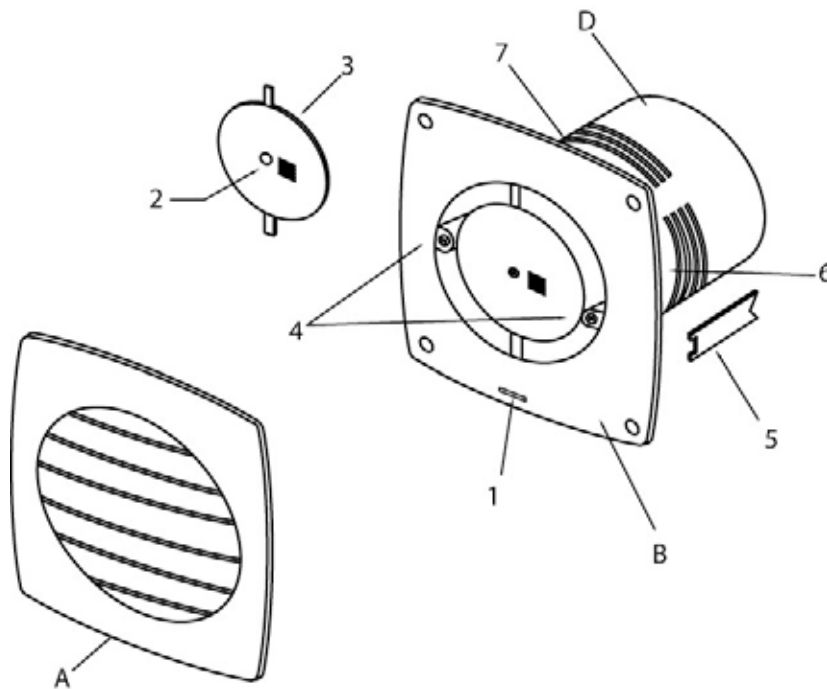

7.0 START-UP

- 7.1. Before power is supplied to the unit, check that the wiring is correct as per the fan connection diagram.
- 7.2. At initial start-up, check that impeller rotation and airflow direction is correct.
- 7.3. Check that the motor amperage draw does not exceed the nameplate rating.

8.0 FAN MAINTENANCE

- 8.1. Inspection of the fan at least once every 12 months is recommended to ensure that the motor, fan blades, and supporting guards, are clean. Any build up of dust and deposits on the blades or guards should be removed using a non-abrasive cleaner.
- 8.2. All fastenings should be checked for tightness. In addition, all rotating items should be checked.
- 8.3. Bearings are of the 'sealed for life' type and will not need a detailed inspection.

WIRING

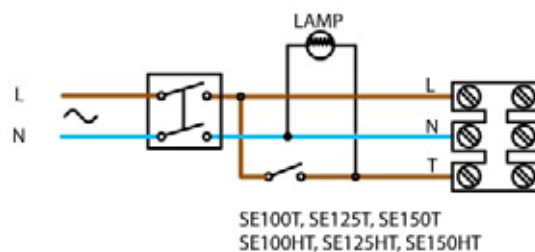
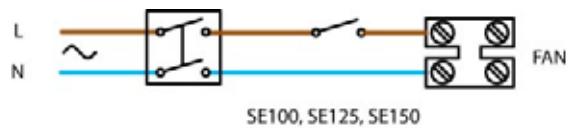

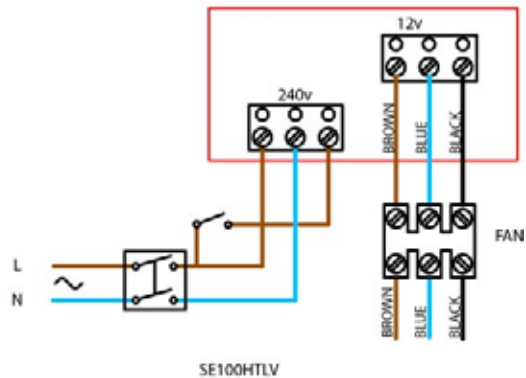
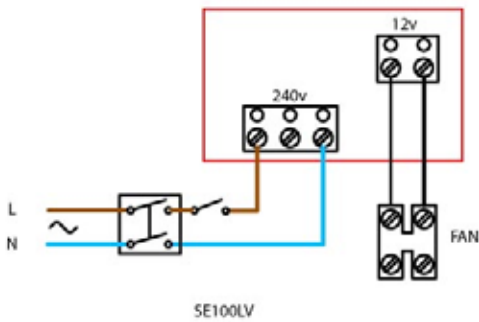
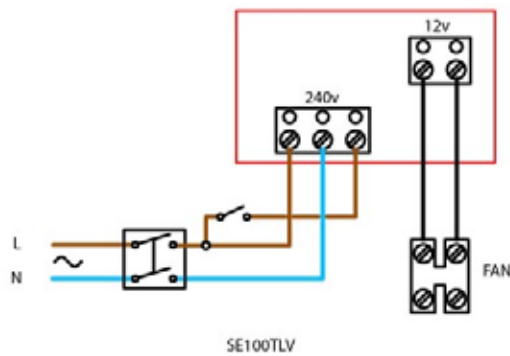
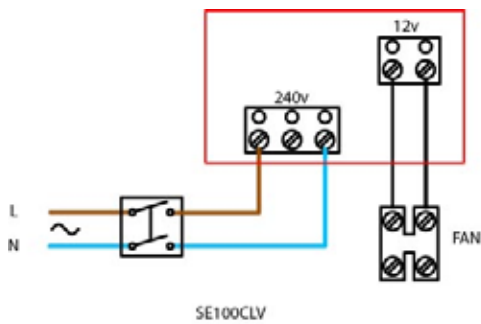

GUARANTEE

Elta Fans Ltd will, free of charge, within a period of 2 years from the date of despatch from their works, repair or at its option replace any goods which are proved to have defects as a result of defective materials or workmanship. The goods MUST be returned to Elta Fans Ltd carriage paid for examination.

Elta Fans Ltd

17 Barnes Wallis Road
Segensworth East Industrial Estate
Fareham, Hampshire, PO15 5ST, United Kingdom

Visit: eltafans.com

e-mail: mailbox@eltafans.co.uk

Applied Technology: **Tel:** +44(0) 1489 566500

Fax: +44(0) 1489 566555

Building Services: **Tel:** +44(0) 1384 275800

Fax: +44(0) 1384 275810

Export: **Tel:** +44(0) 1489 566500

Fax: +44(0) 1489 566555