



Quietflow Twin SQT Installation and Maintenance Instructions

**THESE INSTRUCTIONS MUST BE READ FULLY BEFORE
COMMENCING INSTALLATION**

Code	Supply	FL Amps	Output kW	r/min
SQT125-L	230V/1Ph/50Hz	0.47	0.095	1700
SQT150-L	230V/1Ph/50Hz	0.82	0.160	1650
SQT200-L	230V/1Ph/50Hz	0.82	0.185	1750
SQT250-L	230V/1Ph/50Hz	0.95	0.220	1450
SQT315-22L	230V/1Ph/50Hz	3.10	0.650	1350
SQT315-L	230V/1Ph/50Hz	3.70	0.840	1300
SQT400-L	230V/1Ph/50Hz	6.50	1.000	1360
SQT500-L	230V/1Ph/50Hz	8.10	1.200	890

Code	A	B	C	D	F	G	Weight kg
SQT125-L	425	530	210	125	225	580	16
SQT150-L	525	740	260	150	325	790	26
SQT200-L	525	740	260	200	325	790	26
SQT250-L	550	800	300	250	350	850	30
SQT315-L	800	1000	440	315	600	1050	73
SQT315-22L	800	1000	440	315	600	1050	73
SQT400-L	800	1100	460	400	600	1150	82
SQT500-L	1000	1250	575	500	800	1300	113

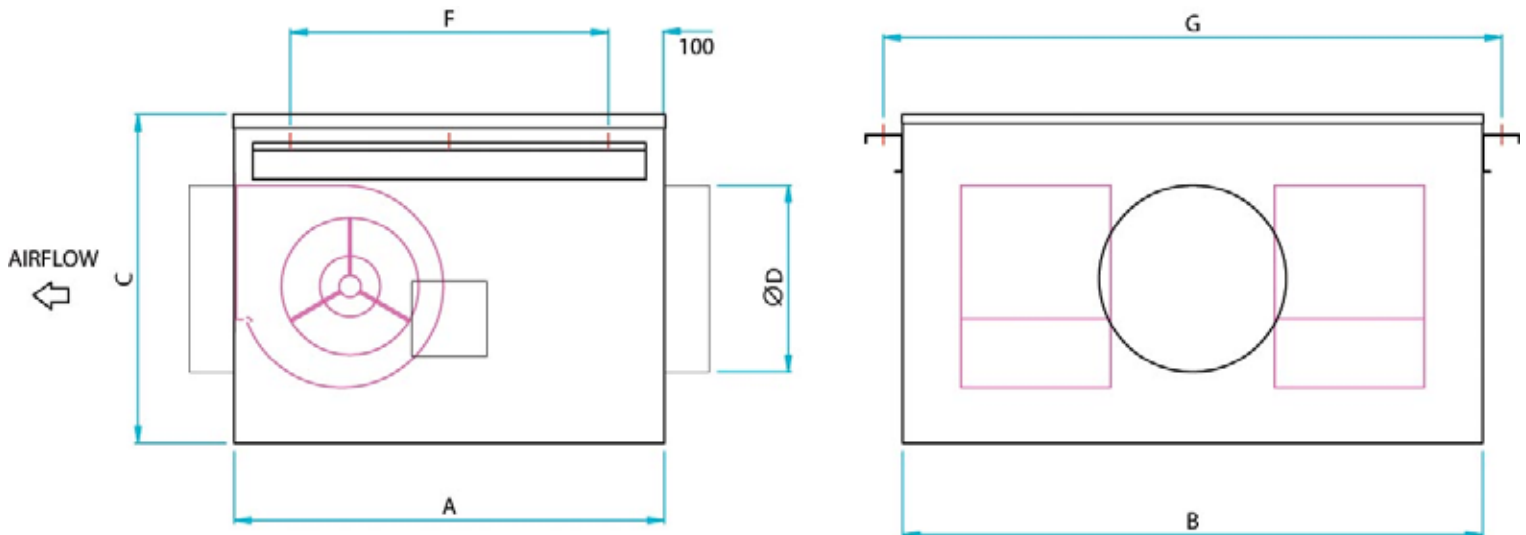

1.0 GENERAL

- 1.1 It is important these Installation and Maintenance Instructions are fully adhered to.
- 1.2 Full details of the unit supplied are shown on the product nameplate. If in doubt about any detail contact Elta Fans Ltd or its agents for clarification.
- 1.3 All electrical installation must be carried out by suitably qualified and competent personnel in accordance with all current statutory requirements.
- 1.4 These instructions cover only the Elta Fans Ltd product and do not include the supply or installation of any safety equipment that may be required e.g. adequate guarding or protection from rotating parts and proper electrical isolation.
- 1.5 Any declarations made by Elta Fans Ltd about product installation and safety, are dependant on the fan equipment being used within installations which themselves meet the requirements of the relevant Standards and Directives of your region.
- 1.6 The fan is designed for use in an ambient temperature of -20°C up to +40°C and up to 95% relative humidity. The fan is not suitable for corrosive or explosive atmospheres.
- 1.7 The installer should provide easy access to the fan to facilitate future maintenance.
- 1.8 The installer should ensure the fan is adequately supported.
- 1.9 This product is not intended for use by persons (including children) with reduced physical, sensory or mental capabilities, or lack of experience and knowledge, unless they have been given supervision or instruction concerning use of the product by a person responsible for their safety. Children should be supervised to ensure that they do not play with the product.

2.0 INSTALLATION

WARNING – The fan must be isolated from the power supply during installation and maintenance. The fan must be earthed in accordance with the local regulations.

- 2.1 Upon receipt, the fan equipment should be visually inspected to check for any damage. Ensure that the impeller is free to rotate.
- 2.2 If there are any queries concerning the fan equipment, Elta Fans Ltd should be contacted prior to the installation.
- 2.3 The fan must be securely mounted in the desired position to suit the application. The fan has gravity operated non-return dampers and is only suitable for horizontal mounting.
- 2.4 Check the details on the motor rating plate to ensure that the correct power supply (voltage, frequency and phase) is available.
An incorrect power supply will lead to permanent damage to the fan motor.
- 2.5 Refer to the appropriate wiring diagram. Ensure that all earth connections are made.
- 2.6 Means for electrical disconnection must be incorporated in the wiring installation in accordance with the relevant wiring and electrical regulations.
- 2.7 Precaution must be taken to locate the exhaust discharge terminal so as to avoid the backflow of gases into the room from the open flue of gas or other fuel burning appliances.

3.0 START-UP

- 3.1 Before power is supplied to the unit, check that the wiring is correct as per the fan connection diagram.
- 3.2 At initial start-up, check that impeller rotation and airflow direction is correct.
- 3.3 Check that the motor amperage draw does not exceed the nameplate rating.

4.0 FAN MAINTENANCE

- 4.1 Inspection of the fan at least once every 12 months is recommended to ensure that the motor, fan blades, and supporting guards, are clean. Any build up of dust and deposits on the blades or guards should be removed using a non-abrasive cleaner.
- 4.2 All fastenings should be checked for tightness. In addition, all rotating items should be checked.
- 4.3 Bearings are of the 'sealed for life' type and will not need a detailed inspection.

WARNING – This fan is fitted with an auto-reset thermal contact which switches the fan off in the event of a fault condition.

Once the motor cools down the fan may start unexpectedly.

Only a suitably qualified and competent person may carry out maintenance after the electrical supply has been isolated.

WIRING

CHANGEOVER PANEL TYPES: 149-AC01/B 149-AC01/B0
 149-AC01/BV 149-AC01/BVO
 149-AC01/BD 149-AC01/BDO
 149-AC01/BDV 149-AC01/BDVO

CONTROLLER TYPES: 149-EL31
 149-EL61

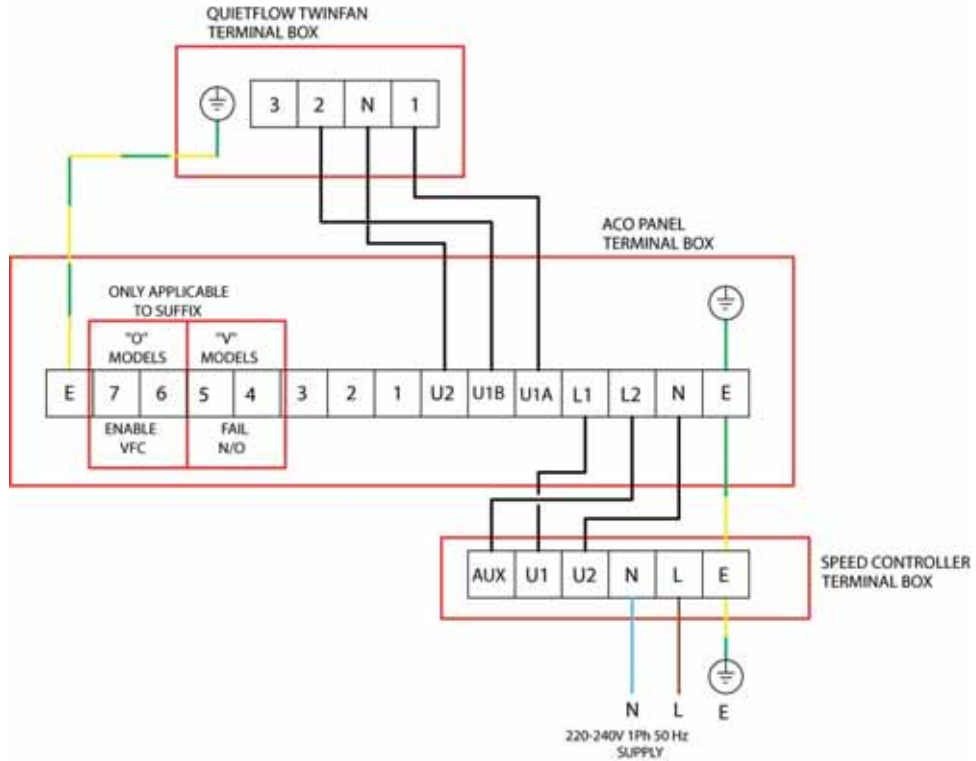

CHANGEOVER PANEL TYPES: 149-AC01/B 149-AC01/B0
 149-AC01/BV 149-AC01/BVO
 149-AC01/BD 149-AC01/BDO
 149-AC01/BDV 149-AC01/BDVO

CONTROLLER TYPES: 149-TC12 149-TC110
 149-TC14 149-TC112
 149-TC18 149-TC116

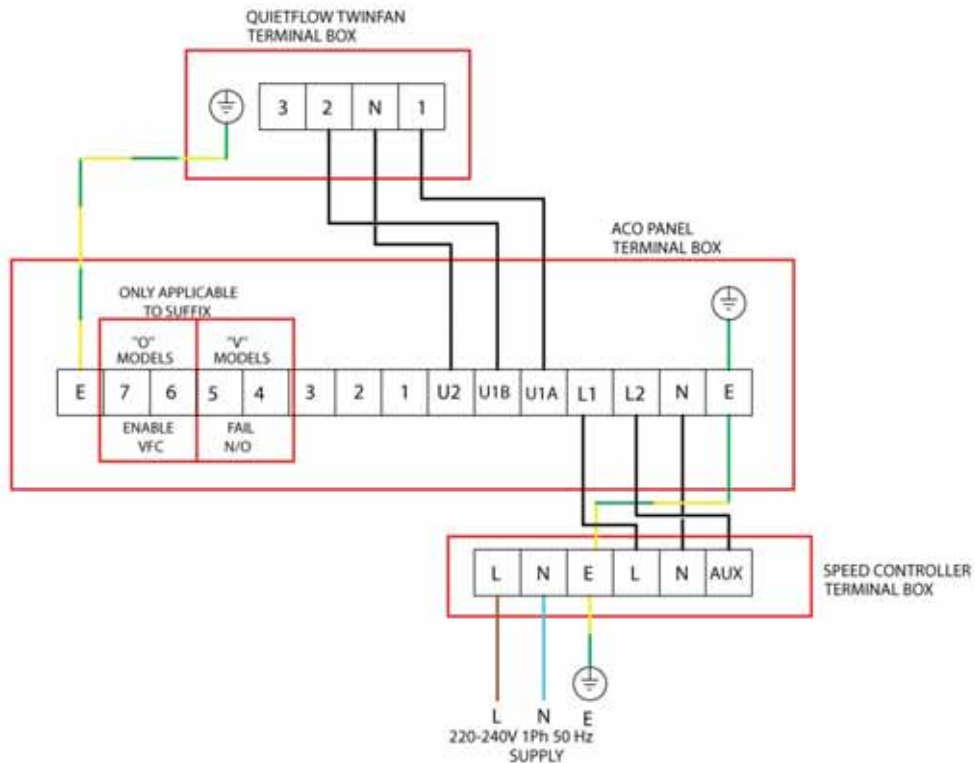

CHANGEOVER PANEL TYPES: 149-AC01/E
 149-AC01/EV
 149-AC01/ED
 149-AC01/EDV

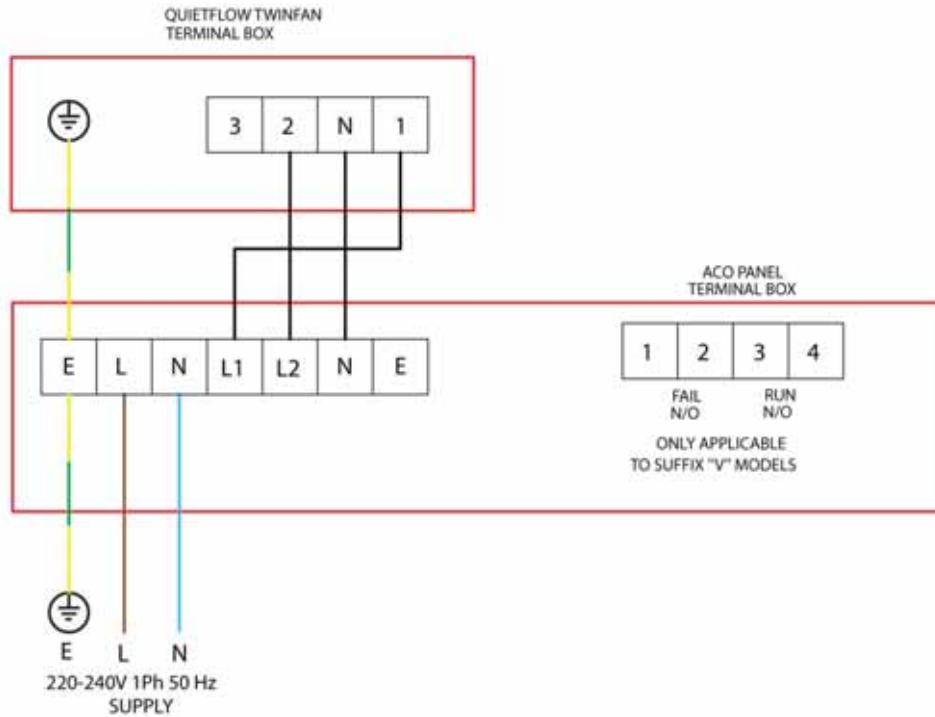

GUARANTEE

Elta Fans Ltd will, free of charge, within a period of 1 year from the date of despatch from their works, repair or at its option replace any goods which are proved to have defects as a result of defective materials or workmanship. The goods **MUST** be returned to Elta Fans Ltd carriage paid for examination.

Elta Fans Ltd

17 Barnes Wallis Road
 Segensworth East Industrial Estate
 Fareham, Hampshire, PO15 5ST, United Kingdom

Visit: eltafans.com

e-mail: mailbox@eltafans.co.uk

Applied Technology: Tel: +44(0) 1489 566500

Fax: +44(0) 1489 566555

Building Services: Tel: +44(0) 1384 275800

Fax: +44(0) 1384 275810

Export: Tel: +44(0) 1489 566500

Fax: +44(0) 1489 566555