



Twinflow STDD & STBD Installation and Maintenance Instructions

**THESE INSTRUCTIONS MUST BE READ FULLY BEFORE
COMMENCING INSTALLATION**

Code	Supply	FL Amps	Input kW	r/min
STDD1/L	230V/1Ph/50Hz	0.37	0.085	2250
STDD2/L	230V/1Ph/50Hz	0.43	0.098	1330
STDD3/L	230V/1Ph/50Hz	1.20	0.25	1220
STDD4/L	230V/1Ph/50Hz	2.70	0.50	1415
STDD5/L	230V/1Ph/50Hz	4.40	0.96	1250
STDD6/L	230V/1Ph/50Hz	5.20	1.10	1310
STDD7/L	230V/1Ph/50Hz	7.00	1.40	820

Code	Supply	FL Amps	Output kW	Motor r/min
STBD1	230V/1Ph/50Hz	2.2	0.25	4 pole
STBD1/2	230V/1Ph/50Hz	3.0	0.37	4 pole
STBD1/2/3/4	230V/1Ph/50Hz	4.4	0.55	4 pole
STBD1/2/3/4	230V/1Ph/50Hz	5.5	0.75	4 pole
STBD1/2/3/4	230V/1Ph/50Hz	7.6	1.1	4 pole

Code	Supply	FL Amps	Output kW	Motor r/min
STBD1	400V/3Ph/50Hz	0.96	0.25	6 pole
STBD1/2	400V/3Ph/50Hz	1.11	0.37	6 pole
STBD1/2/3/4	400V/3Ph/50Hz	1.61	0.55	6 pole
STBD1/2/3/4	400V/3Ph/50Hz	1.95	0.75	6 pole
STBD1/2/3/4	400V/3Ph/50Hz	2.9	1.1	6 pole
STBD2/3/4/5/6	400V/3Ph/50Hz	4.3	1.5	6 pole
STBD2/3/4/5/6	400V/3Ph/50Hz	5.36	2.2	6 pole
STBD3/4/5/6	400V/3Ph/50Hz	7	3	6 pole
STBD5/6	400V/3Ph/50Hz	8.95	4	6 pole
STBD5/6	400V/3Ph/50Hz	12.3	5.5	6 pole

Code	Supply	FL Amps	Output kW	Motor r/min
STBD1	400V/3Ph/50Hz	0.78	0.25	4 pole
STBD1/2	400V/3Ph/50Hz	1.06	0.37	4 pole
STBD1/2/3/4	400V/3Ph/50Hz	1.42	0.55	4 pole
STBD1/2/3/4	400V/3Ph/50Hz	1.77	0.75	4 pole

STBD1/2/3/4	400V/3Ph/50Hz	2.71	1.1	4 pole
STBD2/3/4/5/6	400V/3Ph/50Hz	3.26	1.5	4 pole
STBD2/3/4/5/6	400V/3Ph/50Hz	4.74	2.2	4 pole
STBD3/4/5/6	400V/3Ph/50Hz	6.2	3	4 pole
STBD5/6	400V/3Ph/50Hz	8.15	4	4 pole
STBD5/6	400V/3Ph/50Hz	10.6	5.5	4 pole
STBD5/6	400V/3Ph/50Hz	14.2	7.5	4 pole

Code	A	B	C	D	E	F	G	Weight kg
STDD1/L	425	530	210	175	100	225	580	14
STDD2/L	525	740	260	225	150	325	790	24
STDD3/L	600	800	360	250	150	400	850	36
STDD4/L	700	950	390	350	200	500	1000	48
STDD5/L	800	1000	440	400	325	600	1050	61
STDD6/L	800	1100	440	450	350	600	1150	71
STDD7/L	1000	1250	575	650	400	800	1300	101

Code	A	B	C	D	E	Weight kg
STBD1/L	1000	900	450	600	300	120
STBD2/L	1200	1100	550	800	350	155
STBD3/L	1500	1200	650	1000	350	190
STBD4/L	1500	1550	750	1100	500	250
STBD5/L	2000	2000	1000	1500	700	370
STBD6/L	2000	2000	1000	1500	700	420

STDD

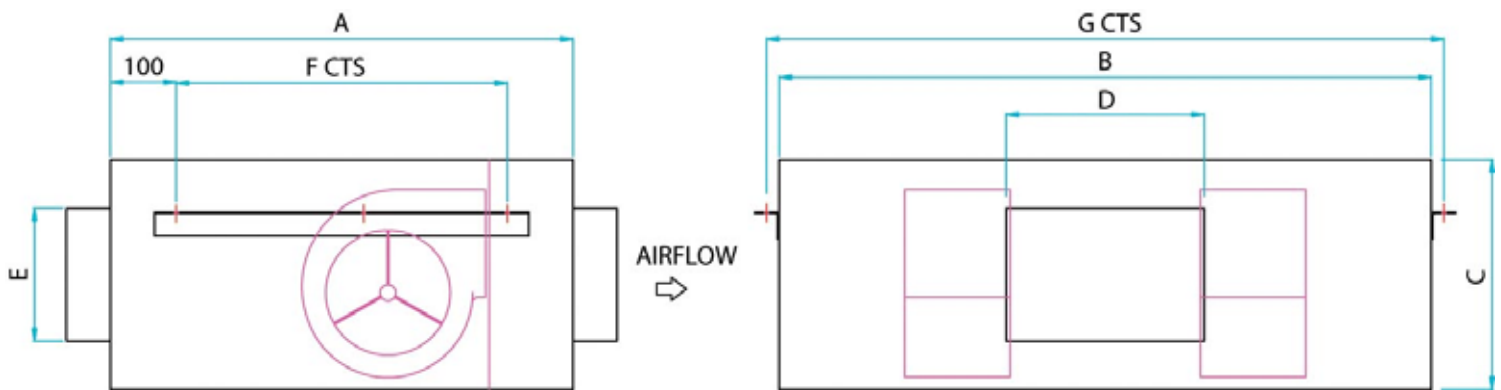

STBD

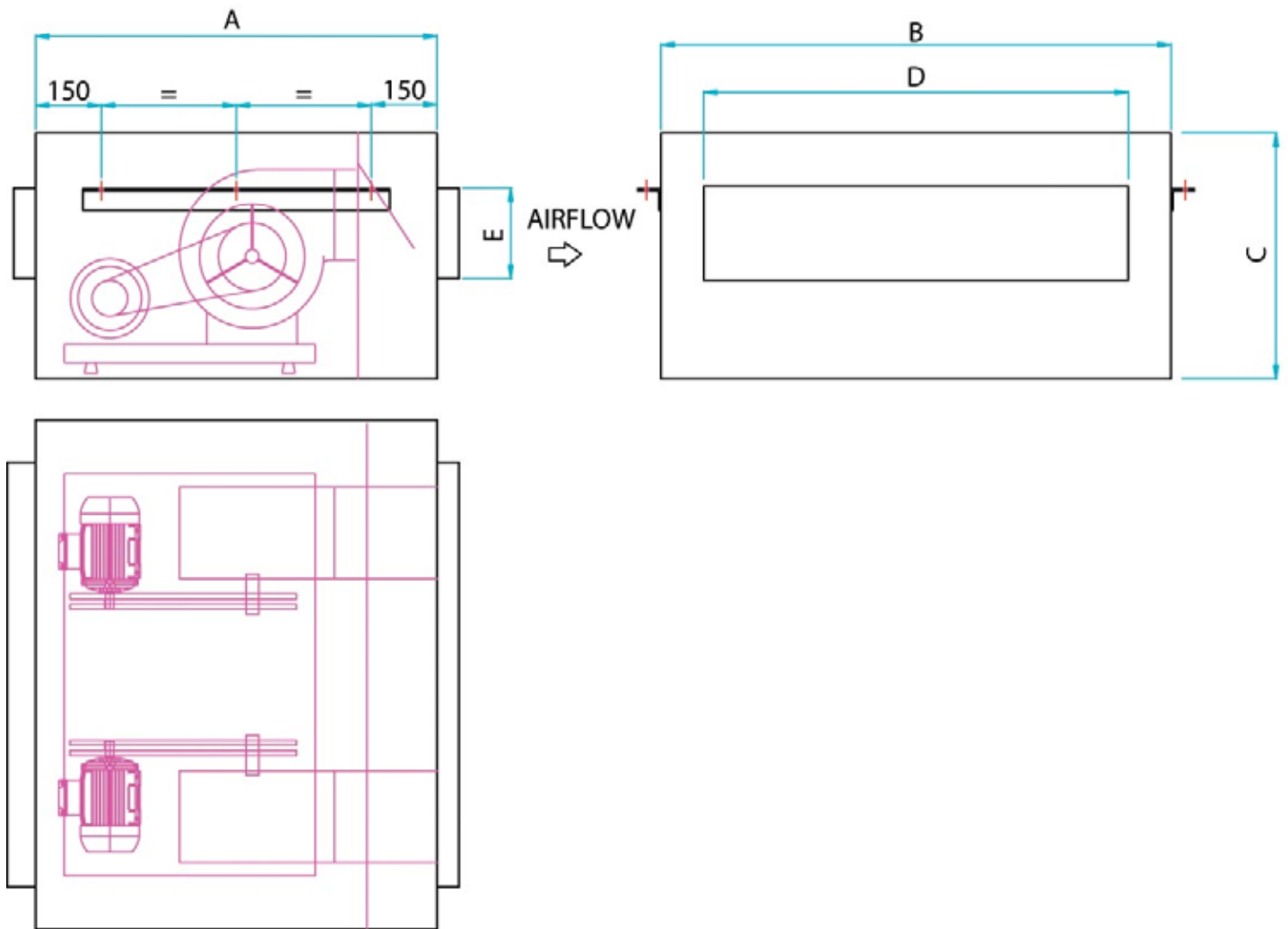

1.0 GENERAL

- 1.1 It is important these Installation and Maintenance Instructions are fully adhered to.
- 1.2 Full details of the unit supplied are shown on the product nameplate. If in doubt about any detail contact Elta Fans Ltd or its agents for clarification.
- 1.3 All electrical installation must be carried out by suitably qualified and competent personnel in accordance with all current statutory requirements.
- 1.4 These instructions cover only the Elta Fans Ltd product and do not include the supply or installation of any safety equipment that may be required e.g. adequate guarding or protection from rotating parts and proper electrical isolation.
- 1.5 Any declarations made by Elta Fans Ltd about product installation and safety, are dependant on the fan equipment being used within installations which themselves meet the requirements of the relevant Standards and Directives of your region.
- 1.6 The fan is designed for use in an ambient temperature of -20°C up to $+40^{\circ}\text{C}$ (STDD direct drive), -20°C up to $+50^{\circ}\text{C}$ (STBD belt drive) and up to 95% relative humidity. The fan is not suitable for corrosive or explosive atmospheres.
- 1.7 The installer should provide easy access to the fan to facilitate future maintenance.
- 1.8 The installer should ensure the fan is adequately supported.
- 1.9 This product is not intended for use by persons (including children) with reduced physical, sensory or mental capabilities, or lack of experience and knowledge, unless they have been given supervision or instruction concerning use of the product by a person responsible for their safety. Children should be supervised to ensure that they do not play with the product.

2.0 INSTALLATION

WARNING – The fan must be isolated from the power supply during installation and maintenance. The fan must be earthed in accordance with the local regulations.

- 2.1 Upon receipt, the fan equipment should be visually inspected to check for any damage. Ensure that the impeller is free to rotate.
- 2.2 If there are any queries concerning the fan equipment, Elta Fans Ltd should be contacted prior to the installation.
- 2.3 The fan must be securely mounted in the desired position to suit the application.
The fan has gravity operated non-return dampers and is only suitable for horizontal mounting.
- 2.4 Check the details on the motor rating plate to ensure that the correct power supply (voltage, frequency and phase) is available.
An incorrect power supply will lead to permanent damage to the fan motor.
- 2.5 Refer to the appropriate wiring diagram. Ensure that all earth connections are made.
- 2.6 Means for electrical disconnection must be incorporated in the wiring installation in accordance with the relevant wiring and electrical regulations.
- 2.7 Precaution must be taken to locate the exhaust discharge terminal so as to avoid the backflow of gases into the room from the open flue of gas or other fuel burning appliances.

3.0 START-UP

- 3.1 Before power is supplied to the unit, check that the wiring is correct as per the fan connection diagram.
- 3.2 At initial start-up, check that impeller rotation and airflow direction is correct.
- 3.3 Check that the motor amperage draw does not exceed the nameplate rating.

4.0 FAN MAINTENANCE

- 4.1 Inspection of the fan at least once every 12 months is recommended to ensure that the motor, fan blades, and supporting guards, are clean. Any build up of dust and deposits on the blades or guards should be removed using a non-abrasive cleaner.
- 4.2 All fastenings should be checked for tightness. In addition, all rotating items should be checked.
- 4.3 Bearings are of the 'sealed for life' type and will not need a detailed inspection.

5.0 BELT TENSION AND ALIGNMENT

- 5.1 The belt tension and alignment should be checked:
 - When fitting new belts or when installing and starting a fan for the first time.
 - After the first 30 minutes of operation.
 - At least every 6 months.
- 5.2 The pulleys must be checked for correct alignment before checking the belt tension and again after making any adjustments. A straight edge should be placed across the faces of both pulleys to ensure that both shafts and pulleys are parallel and in alignment.
- 5.3 Measure the centre distance between pulleys.
- 5.4 Multiply the pulley centre distance in metres by 16 to obtain the required belt deflection in mm.
- 5.5 Set the required belt deflection on the tension gauge.
- 5.6 With the tension gauge at right angles to the belt and at the mid point between pulleys, apply a force so that the set deflection is achieved.
- 5.7 Check the force applied against the tabulated values below.
- 5.8 Increase the pulley centre distance until the correct force value is obtained.
- 5.9 Run the drive for 30 minutes and re-tension if required.

Belt Section	Force required to deflect belt 16mm per metre of span		
	Small Pulley Dia - mm	Newton - N	Force - kgf
SPZ	67 to 95	10 to 15	1.0 to 1.5
	100 to 140	15 to 20	1.5 to 2.0
SPA	100 to 132	20 to 27	2.0 to 2.7
	140 to 200	28 to 35	2.8 to 3.5

6.0 BELT REPLACEMENT

- 6.1 Worn or damaged belts will require periodic replacement.
- 6.2 Loosen the motor bolts and move the motor towards the fan until the belts can be easily removed by hand without using a tool.
- 6.3 If the drive is fitted with more than one belt, all belts must be replaced simultaneously as a matched set.
- 6.4 Tension and align the drive per Clause 5.0 above, ensuring that all fasteners are tightened.

WARNING – STDD fans are fitted with an auto-reset thermal contact which switches the fan off in the event of a fault condition.

Once the motor cools down the fan may start unexpectedly.

STBD fans are fitted with standard metric frame foot mounted motors.

Fuses /circuit breakers are used to provide short circuit protection only. A starter panel with overload protection should be used to protect the motor.

Only a suitably qualified and competent person may carry out maintenance after the electrical supply has been isolated.

WIRING

STDD & STBD 1PH

FIXED SPEED CONNECTION CHANGEOVER PANEL TYPES: 149-AC01/A 149-AC01/AV 149-AC01/AD 149-AC01/ADV

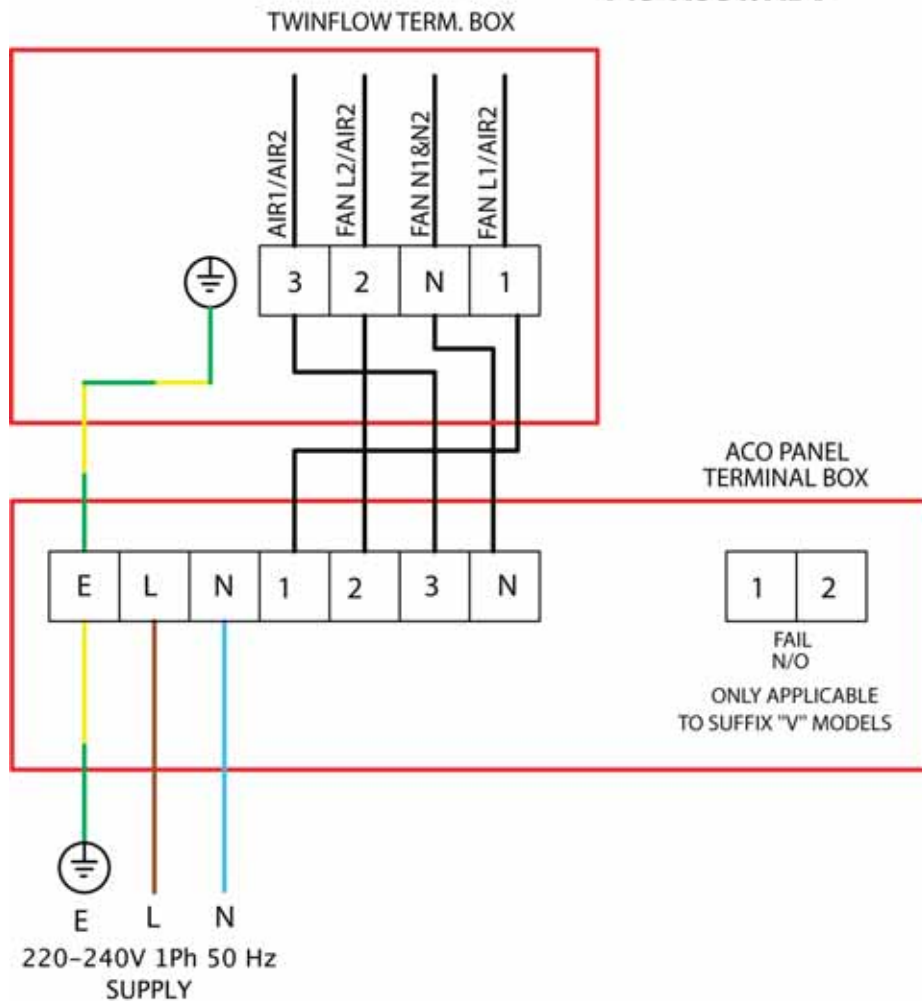

STBD 3PH

FIXED SPEED CONNECTION
CHANGEOVER PANEL TYPES: 149-AC03/B 149-AV03/BO
 149-AC03/BV 149-AC03/BVO
 149-AC03/BD 149-AC03/BDO
 149-AC03/BDV 149-AC03/BDVO

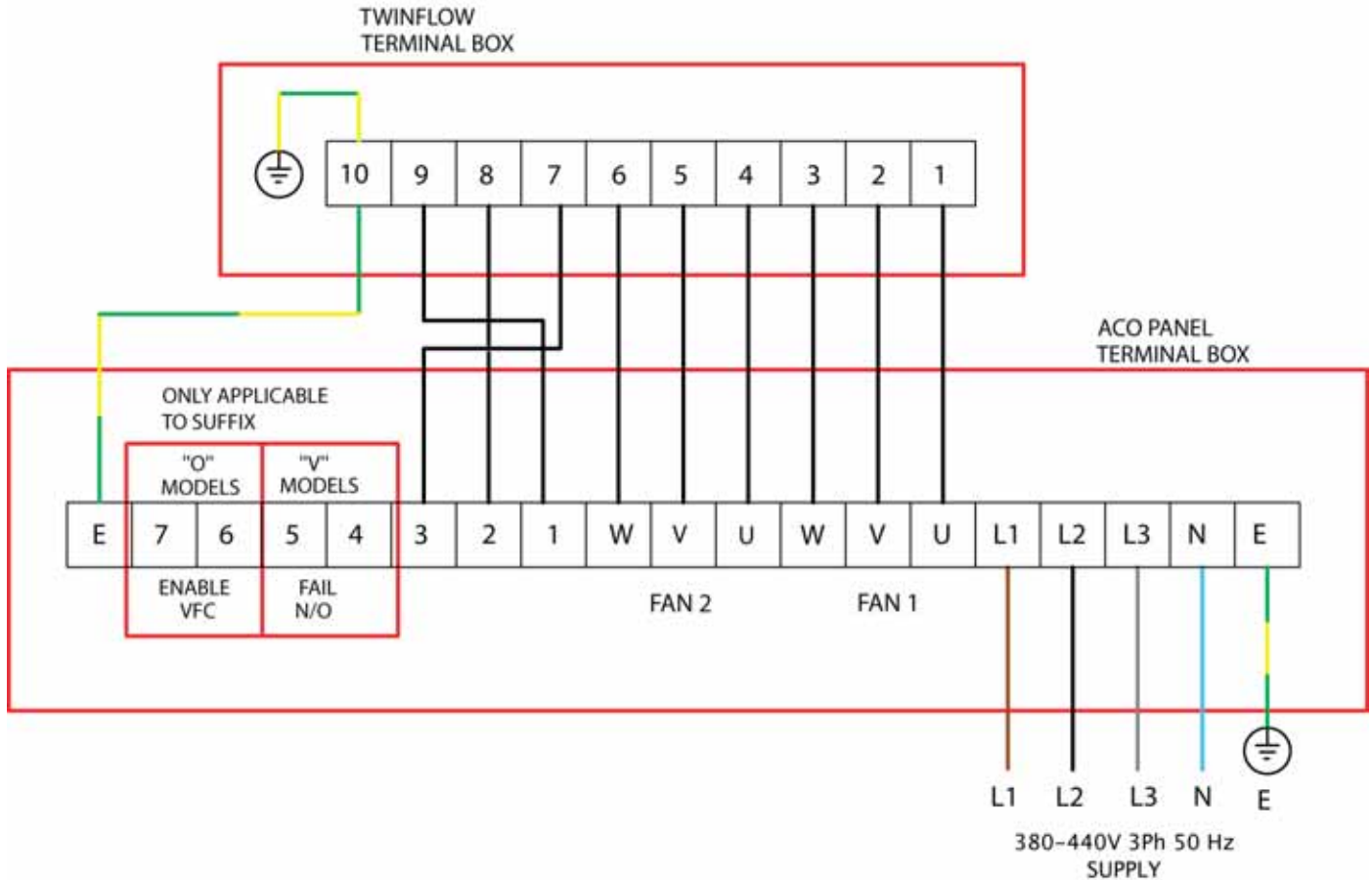

GUARANTEE

Elta Fans Ltd will, free of charge, within a period of 1 year from the date of despatch from their works, repair or at its option replace any goods which are proved to have defects as a result of defective materials or workmanship. The goods **MUST** be returned to Elta Fans Ltd carriage paid for examination.

Elta Fans Ltd

17 Barnes Wallis Road
 Segensworth East Industrial Estate
 Fareham, Hampshire, PO15 5ST, United Kingdom

Visit: eltafans.com

e-mail: mailbox@eltafans.co.uk

Applied Technology: **Tel:** +44(0) 1489 566500

Fax: +44(0) 1489 566555

Building Services: **Tel:** +44(0) 1384 275800

Fax: +44(0) 1384 275810

Export: **Tel:** +44(0) 1489 566500

Fax: +44(0) 1489 566555